



Main Features:-

- ◆ Flanged PN16
- ◆ Cast Iron Body, 304 Stainless Steel Basket
- ◆ 60 Mesh (100 Mesh spare baskets available)
Rated PN16
- ◆ Maximum Temperature 220° C

*Temperature and pressure determined by valve body, seat etc.

Suitable Applications & Approvals:



SERIES: 30174—30175

MANUFACTURER: **AVOL**
INDUSTRIAL VALVES

VALVE DIMENSIONS

Name	Materials
Body	Cast Iron
Gasket	Fibre
Screen	Stainless Steel
Cover	Cast Iron
Bolt	Steel
Drain Plug	Iron

SIMPLEX (30174) Dimensions

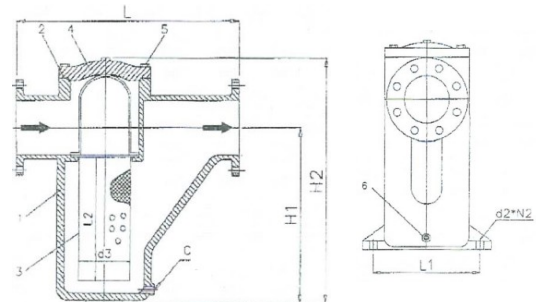

Size	H1	H2	L	C	L1	d2	N2	d3	L2	Kg
2"	178	260	260	3/8"	-	-	-	75	120	26
2 1/2"	190	287	330	3/8"	-	-	-	96	165	28.5
3"	250	350	350	1/2"	-	-	-	96	180	30
4"	300	420	400	1/2"	-	-	-	110	220	48
6"	555	700	556	3/4"	315	Ø22	2	168	400	81
8"	560	820	650	3/4"	352	Ø22	2	210	450	110

DUPLEX (30175) Dimensions

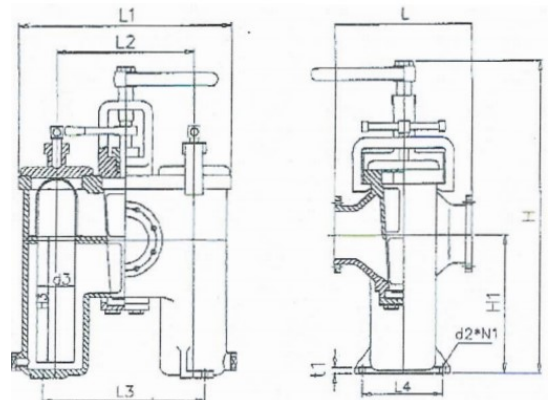

Size	L	L1	L2	L3	L4	H	H1	t1	d2
2"	272	420	255	305	155	550	280	15	15
3"	315	470	305	345	170	640	255	15	15
4"	400	5220	350	430	200	880	370	18	19
6"	500	750	480	510	250	1060	430	22	22
8"	670	1030	610	955	350	1350	633	30	22

Size	N1	d3	H3	Kg
2"	4	95	200	55
3"	4	95	200	107
4"	4	107	350	169.5
6"	4	164	400	390
8"	4	225	600	500

T +44 (0)1386 552369

W www.allvalves.co.uk

E sales@allvalves.co.uk

F +44 (0)1386 554227